

Simple  friendly

High-Performance Palletizing Robots



series



series

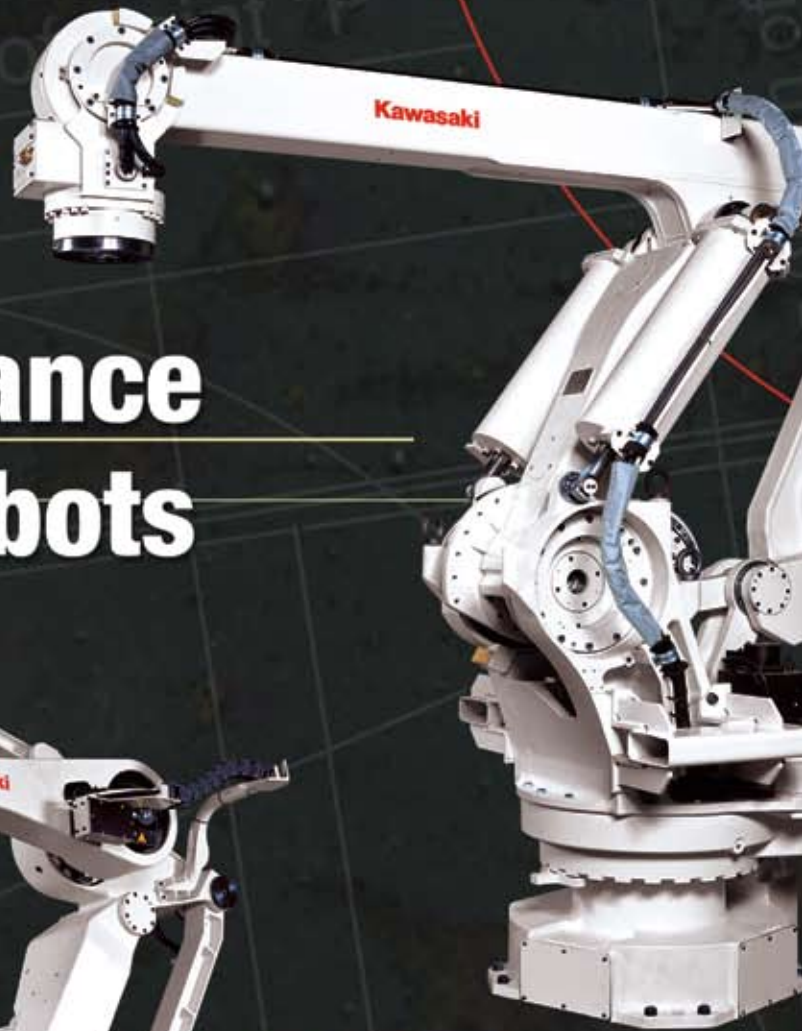

 **Kawasaki**

Kawasaki Robotics (USA), Inc.

simply the highest performance robots on the planet



Kawasaki Robotics (USA), Inc.

System Layout Examples



Multi-Product Palletizing (5-Lane)



Glass Bottle Palletizing

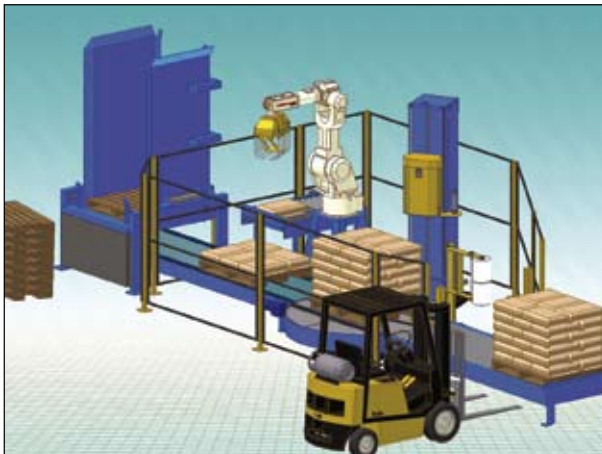

Bag Palletizing - FD50N

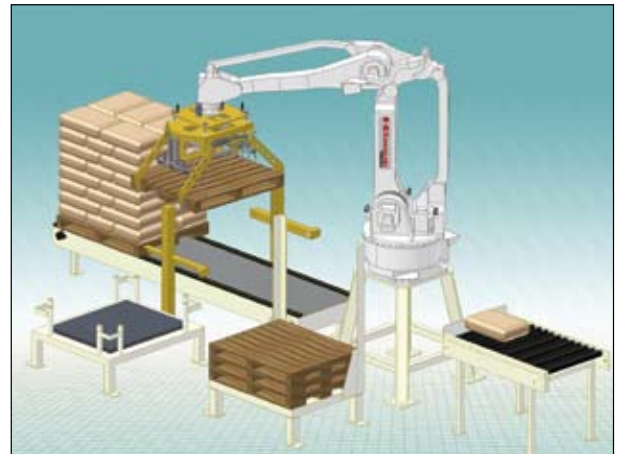

Bag Palletizing - ZZD130S

Kawasaki Robot Palletizing Advantages

- The long arm design provides the option to palletize up to five different full size pallets with one robot.
- Kawasaki's AS Language is a powerful yet user friendly means of programming which allows for quick program creation and "on-the-fly" editing.
- The high payload capabilities enable the robot to manipulate multiple products during one pick cycle, resulting in higher throughput.
- The powerful Kawasaki "D" Controller offers a variety of communication, interfacing, and networking options (see D Controller Brochure or visit www.kawasakirobotics.com).
- Over 40 years of proven reliability and performance.

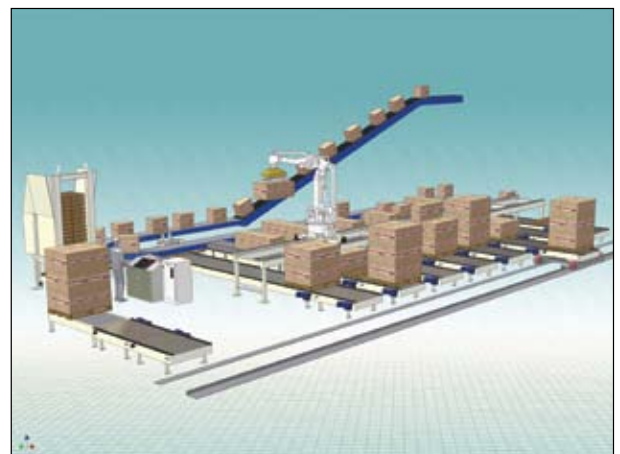

Box Palletizing with 7th Axis Rail



High-Performance Palletizing Robots



FD50N

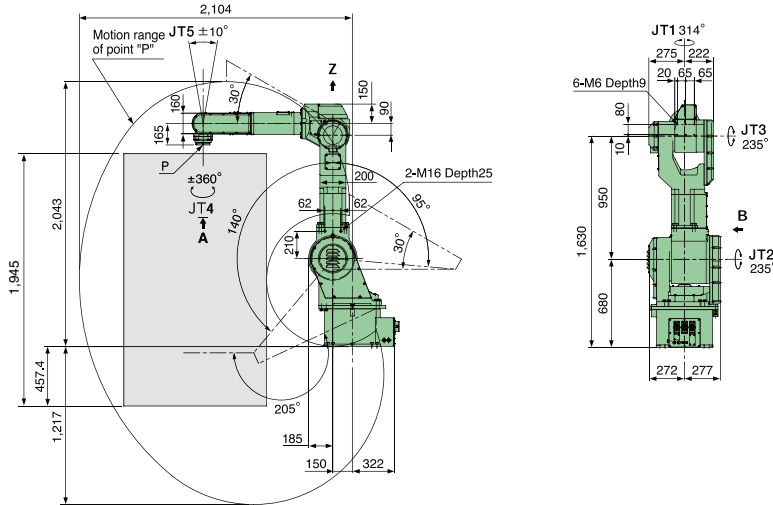

ZZD130S and ZZD250S

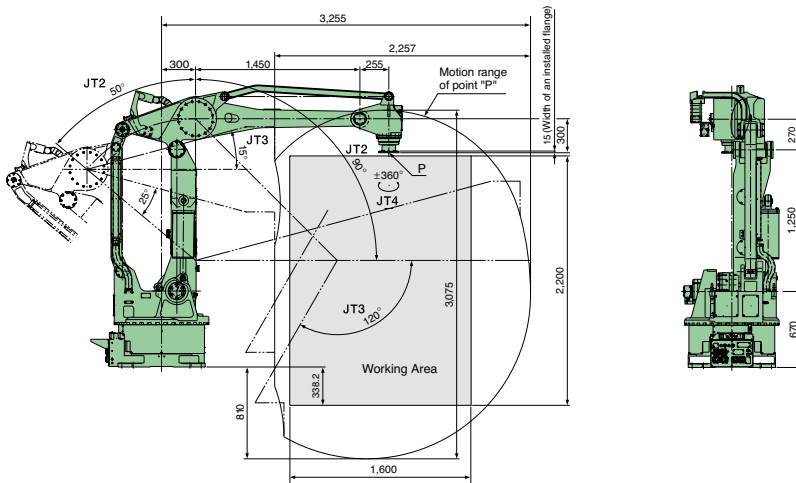

MD400N

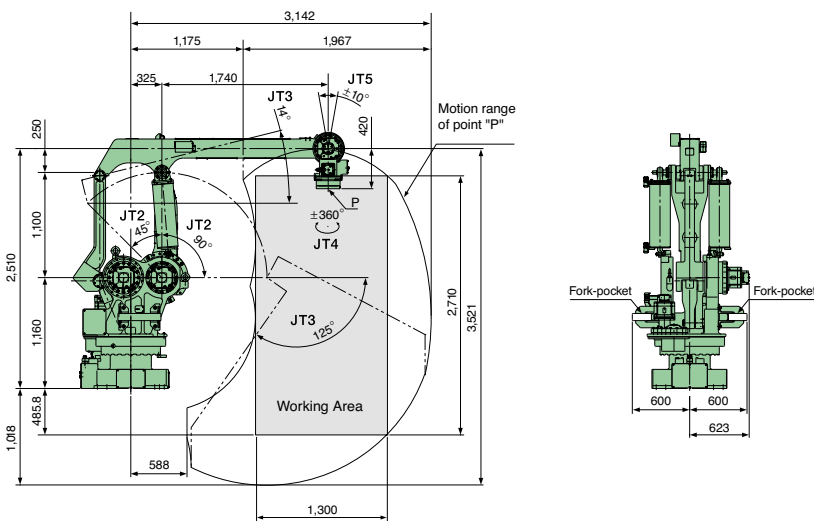

simply the highest performance robots on the planet

Standard Features

- ZZD130S/ZZD250S - 4 Axis (optional 5th axis traverse)
- MD400N - 5 Axis (optional 6th axis traverse)
- FD50N - 5 Axis (optional 6th axis traverse)
- High-Speed Articulated Arm
- Payload Capacity 50-400 kg (110-880 lbs)
- Electric AC Servo Drive Motors & Encoders
- High-Performance D Controller
- Large Work Envelope
 - FD50N - 3,260 mm Vertical Range, 2,104 mm Horizontal Reach
 - ZZD130S/ZZD250S - 3,075 mm Vertical Range, 3,255 mm Horizontal Reach
 - MD400N - 3,521 mm Vertical Range, 3,142 mm Horizontal Reach
- Heavy Duty Cycle
 - High Wrist Torque and Inertia Capacity
 - High Speed Wrist
 - Maximum Payload Capacity Rated at Full Speed and Full Reach
- Simple, Low-Cost Maintenance
 - 96,000 Hours MTBF
 - 10,000 Hour Maintenance Intervals
 - Fittings for Easy Lubrication
- Space Saving Design
 - Small Footprint
 - Minimal Dead Zone
- Production Advantages
 - High Speed Operation
 - Rapid and Adaptive Acceleration and Deceleration Rates
 - All Digital Servo Control
 - 5-Lane Pallet Stacking Capability
 - Remote Web-Based Diagnostics and System Monitoring (optional)
 - Automatic Program Back-Up Feature
- Programming
 - Simple "Block Step" Teaching
 - Advanced Kawasaki "AS Language"
 - RS-232 Port for PC Communication
 - Ethernet Communication
 - Pallet Building Software
 - Menu-Driven Interface
 - On-Screen Diagnostics
- Safety
 - Rotational Hard Stops and Software Limits
 - Collision Detection Software (optional)
 - Three-Position Teach Pendant Safety Switch
 - Hardwired Emergency Circuits for Peripheral Devices
 - UL Approved

FD/ZZD/MD Series Specifications

Type		FD50N		ZZD130S		ZZD250S		MD400N	
Arm Type		Articulated Type							
Degrees of Freedom		5 Axes (6 Axes : Option)		4 Axes (5 Axes : Option)				5 Axes (6 Axes : Option)	
Axis Work Envelope and Max. Speed	Axis	Max. Stroke	Max. Speed	Max. Stroke	Max. Speed	Max. Stroke	Max. Speed	Max. Stroke	Max. Speed
	JT1 : Arm rotation	+157°~-157°	180°/s	±180°	135°/s	±180°	95°/s	±180°	80°/s
	JT2 : Arm out-in	+140°~-95°	150°/s	+90°~-50°	110°/s	+90°~-50°	95°/s	+90°~-45°	70°/s
	JT3 : Arm up-down	+30°~-205°	180°/s	+15°~-120°	130°/s	+15°~-120°	95°/s	+14°~-125°	70°/s
	JT4 : Wrist swivel	+360°~-360°	350°/s	±360°	400°/s	±360°	190°/s	±360°	180°/s
	JT5 : Wrist bend	+10°~-10°	N/A	N/A	N/A	N/A	N/A	N/A	±10° *
JT7 : Arm traverse	Standard 2,000 mm	1,000 mm/s							
Position Repeatability		±0.15 mm (at the tool mounting surface)		±0.5 mm					
Working Area	Width	1,100 mm		1,800 mm				1,300 mm	
	Depth	1,100 mm		1,600 mm				1,300 mm	
	Height	1,944.7 mm		2,200 mm				2,710 mm	
Max. Reach		2,104 mm		3,255 mm				3,142 mm	
Max. Payload		50 kg		130 kg		250 kg		400 kg	
Wrist Moment of Inertia		4.4 kg·m ² (JT4)		50 kg·m ²		100 kg·m ²		200 kg·m ²	
Weight		580 kg		1,350 kg				2,650 kg	
Palletizing Capacity		2,400 cycle/hour (50 kg)		1,800 cycle/hour (60 kg)		850 cycle/hour (250 kg)		740 cycle/hour (400 kg)	
				1,500 cycle/hour (130 kg)					
Environmental Conditions		0-45°C, 35-85% Relative Humidity without Condensation							
Options		Power/Signal Cable Length: (10 m, 15 m), Built-in Valve, Ceiling Mount, Mechanical Stop JT1, JT2		Power/Signal Cable Length: (10 m, 15 m), Mechanical Stop (ZZD JT1) (MD JT1/JT2/JT3), End Stroke Limit Switch (ZZD JT1) (MD JT1/JT2/JT3), Special Color, Traversing Track					
Color		Kawasaki Standard							

1 N·m = 0.102 kgf·m 1 kg·m² = 0.102 kgf·m·s² 1 kgf = 2.2 lbf 1 m = 3.28 ft.

*Operation angle of the JT5 is more or less than 10°, perpendicular to the ground.

For More Information Please Contact Kawasaki Robotics (USA) Inc.

Palletizing Series

simply the highest performance robots on the planet

High-Performance Palletizing Robots

In today's highly competitive marketplace the demand for just-in-time deliveries, flexible packaging, the freshest products, and the highest production line efficiencies are all key to the success of companies and their products. For these reasons, as well as many others, Kawasaki Robots are becoming the brand of choice for Palletizing and Depalletizing applications around the world. Kawasaki Robotics provides four unique robots designed specifically for palletizing applications. These units are the FD50N, ZD130S, ZD250S, and the MD400N. With high payload capacities and an industry leading work range, Kawasaki has the ideal robot for most any palletizing application.

High-Speed Operation

The Kawasaki Palletizing Robots are among the fastest and most reliable units in the industry. The FD50N Robot is capable of 2,400

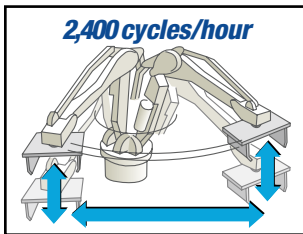

cycles per hour with a 50 kg (110 lbs) payload and the ZD130S Robot is capable of 1,800 cycles per hour with a 60 kg (133 lbs) payload. This high performance is combined with unmatched quality offering greater than 96,000 hours MTBF.

Cycles Per Hour Calculations

FD50N - 2,400 cycles/hour (50 kg)

- 900 mm between the pick-up & drop-off locations
- 75 mm vertical moves at each station.

ZD130S - 1,800 cycles/hour (60 kg)

- 2000 mm between the pick-up & drop-off locations
- 400 mm vertical moves at each station.

Compact Applications

The Kawasaki FD50N is designed specifically for applications where a compact, high-speed, palletizing robot is required. Despite its slim space-saving design, the FD50N can manipulate loads up to 50 kg (110 lbs) and create pallet stacks over seven feet tall. The unique 5-axis design can be floor or ceiling mounted and is ideal for palletizing and case-packing applications.

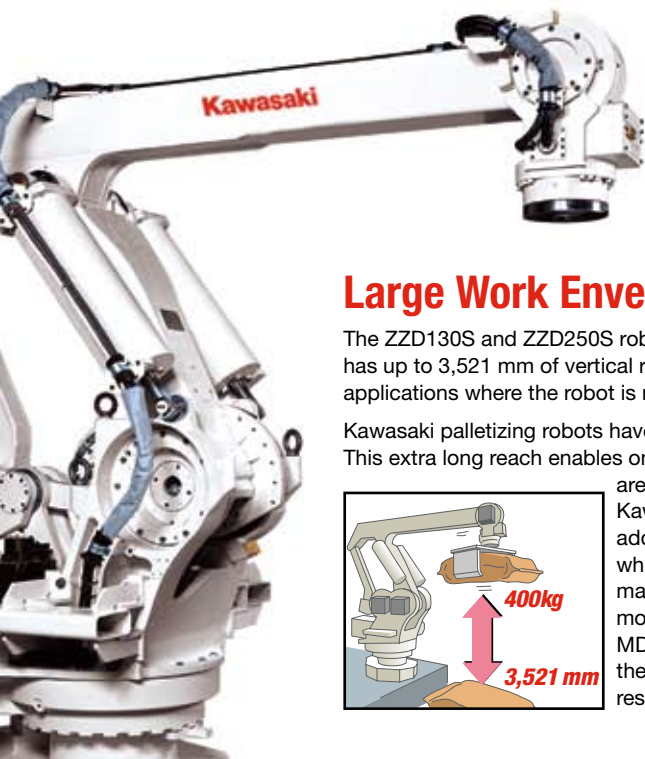
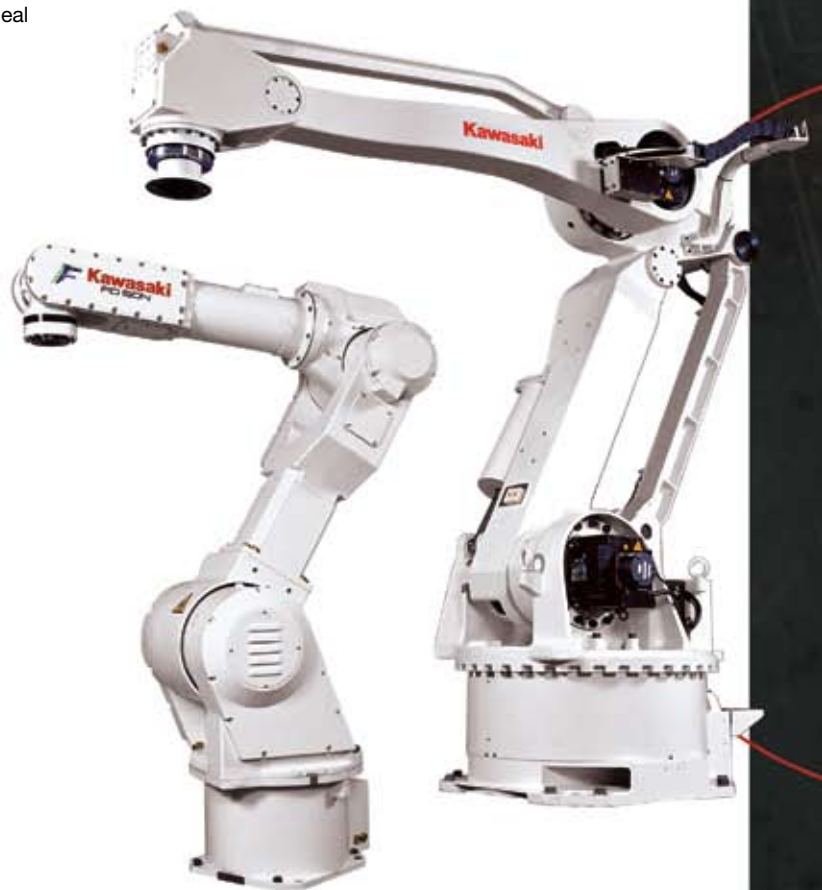

Large Work Envelope with High Payload

The ZD130S and ZD250S robots can manipulate products vertically up to 3,075 mm, while the MD400N robot has up to 3,521 mm of vertical range. The high vertical reach capability is ideal for tall pallet creation and multi-lane applications where the robot is required to reach over incoming and outgoing production lines.

Kawasaki palletizing robots have a horizontal reach of up to 3,255 mm, which is the longest reach in their class. This extra long reach enables one Kawasaki robot to be used in applications where up to 5 outgoing pallet lanes are required. This unique capability contributes to the flexibility and efficiency of the Kawasaki robot design. When the robot is to be used for multi-lane palletizing the addition of a 4th or 5th lane can often significantly increase production efficiencies while reducing the payback period. Using a Kawasaki Robot for multi-lane palletizing may also significantly contribute to the cost justification of the project. The ZD models are ideal for typical medium to heavy palletizing loads, while the high capacity MD400N Robot can handle up to 400 kg (880 lbs). The high payload capabilities of these robots allows for multiple product picks and/or complete pallet layer handling, resulting in fewer cycles per completed pallet.

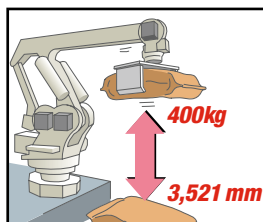



Kawasaki Robotics (USA), Inc.

28140 Lakeview Drive
Wixom, Michigan 48393

Phone: (248) 446-4100

Fax: (248) 446-4200

Louisville, Kentucky

Phone: (502) 893-3889

Atlanta, Georgia

Phone: (770) 218-5887

San Jose, California

Phone: (408) 432-0990

Canada

Phone: (905) 465-0880

Mexico

Phone: (52) 33 3110-1895

www.kawasakirobotics.com